

TOPAS ®

SAG 410/U 固态气溶胶发生器

用户手册

中国总代理: **Nano**电子商城

Tel: 400-660-9565, 13916696061

Fax: 021-5206-1832

E-mail: micron365@gmail.com

Website: <http://www.19mro.com>

Contents

| | |
|--|------|
| Safety | iii |
| 1 Introduction..... | 1-1 |
| 2 Product Description | 2-1 |
| Feeding and Dispersing Unit | 2-2 |
| Control Unit | 2-4 |
| 3 Operation and Maintenance | 3-1 |
| Unpacking | 3-1 |
| Start up and Operation | 3-2 |
| Maintenance..... | 3-8 |
| Dismounting and Mounting Feeding and Dispersing Unit | 3-10 |
| Transport..... | 3-10 |
| 4 Feeding and Dispersing | 4-1 |
| Operation of the SAG 410/U | 4-1 |
| Stopping the Aerosol Generation | 4-2 |
| Calibration of the Feeding Unit..... | 4-3 |
| 5 Troubleshooting..... | 5-1 |
| 6 Specification | 6-1 |
| Technical Data | 6-1 |
| Accessories (optional) | 6-2 |
| 7 Appendix | 7-1 |
| Option Remote Control..... | 7-1 |
| Description of the Interface (SUB-D-Socket 15 Pins)..... | 7-3 |
| Characteristics of the Dispersing Nozzle..... | 7-5 |
| EG-Konformitätserklärung..... | 7-6 |
| EC Declaration of Conformity..... | 7-6 |

Manufacturer and Service Address

Topas GmbH

Technologie-orientierte Partikel-, Analysen- und Sensortechnik
Oskar-Röder-Str. 12
01237 Dresden
GERMANY

Telephone +49 (351) 21 66 43 - 0
Telefax +49 (351) 21 66 43 55
E-mail office@topas-gmbh.de
Internet www.topas-gmbh.de

Alternatively please ask your local distributor for further information.

Warranty and Liability

Topas GmbH warrants that this product, under normal use and service as described in this manual, shall be free from defects in workmanship and material for a period of twelve (12) months from the date of shipment to the customer.

If the device is delivered by a transportation company, damages cannot be excluded. Therefore, the packaging must be thoroughly checked for external damage immediately after delivery. Any visible signs of transport damage should be reported to the insurance company or to us. Also the damaged instrument should not be switched on and the agent must be informed about it.

Caution: *Please read this instruction manual carefully before using the device. Topas GmbH does not assume any liability for damages caused by improper operation, application, cleaning or use of unsuitable materials.*

Reproduction, translation or transmission of this manual in whole or in part, in any form or by any means is prohibited without the written permission of Topas GmbH.

© January 10 Topas GmbH. All rights reserved.
410 10 01 EHU

Intended Use

The Solid Aerosol Generator SAG 410 (device for dosing and dispersing dusts) is intended to be used for generating defined aerosols for test purposes (filter testing, dust holding capacity tests, generation of tracer particles etc.).

For aerosol material dry and free flowing substances with particle size <100 µm can be used. The use of sticky or aluminium attacking substances is excluded.

The use of other substances than mentioned above is in the responsibility of the user. In no way biological or radioactive dusts have to be used.

All responsibility regarding the handling of the aerosol substance and the application of the generated dusts must be assumed by the user.

The apparatus must not be used in explosive environments and not with inflammable or hot gases.

Safety

Caution: *Danger of electric shock!*

Disconnect the power cable from the mains supply before performing any cleaning or service activity.

The dispersing process may cause electrostatic charging of the injector and the aerosol by tribo-electric effects.

Check the proper attachment of the protective earthing conductor (designated by the green-yellow insulation) to the dispersing nozzle before setting the device into operation.

Caution: *Fire and explosion hazard!*

Neither use inflammable nor hot gases as dispersant at any time.

Do not operate the apparatus in any explosive gas atmosphere.

Caution: Risk of injury by moving components!

During the operation of the generator any touching of the moving components (powder reservoir, dosing ring drive, feeder) either by fingers or implements is prohibited. The operation of the device is only permissible with the cover closed.

Caution: Avoid the inhalation of the generated aerosols!

Make provisions for an adequate exhausting of the aerosol. Make sure that the aerosol outlet piping from the device is not clogged, closed or substantially throttled. The safety data sheets of the aerosol substances applied have to be obeyed.

Important: Use only proper aerosol material for the operation of the aerosol generator.

- *Use only dry and free flowing dusts with particle size <math>< 100 \mu\text{m}</math>*
 - *Do not use adhesive or aluminium-reactive substances.*
 - *In order to avoid deposits, the internal surfaces of the equipment into which the generated aerosol is to be passed in must be completely dry.*
-

1 Introduction

Dust is defined as a dispersion of fine solid particles in gas. Although dust usually represents a pollution of our environment, it is often needed for tests and research. For that the particle concentration and the particle size should be known and adjusted. A typical example for such an application is determining the efficiency of various filters.

Generation of such special dusts requires two different steps – feeding and dispersing the powder.

This generator allows to dose and disperse smallest amounts and powders which usually could not be processed with common instruments. This is achieved by utilisation of a new principle for powder dosing.



Figure 1: Solid Aerosol Generator SAG 410/U

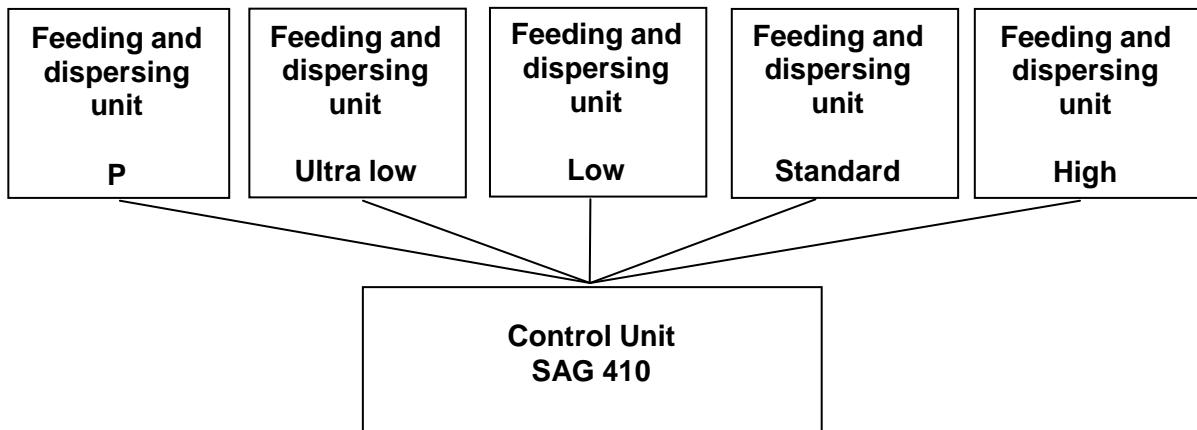

Figure 2: Scheme of the dust disperser series SAG 410

The feeding and dispersing unit can be easily dismantled by the user and changed. So varying feeding ranges can be realized with one instrument.

You can also control the SAG 410/U with a remote control system if you have ordered this additional device. Please ask Topas or the local distributor for more information about these options.

2 Product Description

The innovative idea of the SAG 410/U is the use of a special rotating stainless steel ring for dosing. This technical solution allows to feed the dispersing nozzle with tiny amounts of dust samples. By adjusting the rotation speed of the ring the sample feed can be controlled in a wide range. The design of the SAG 410/U warrants accurately and reproducible aerosol generation even for long time operations.

The control board on the front panel enables an easy operation of the generator. By using the external interface the SAG 410/U can also be operated by a remote control system or a computer.

Feeding Range of the Generator

Details referring to the feeding range of the SAG 410/U are given in the Chapter "Technical Data". It should be noted that the given data depend on the used powders.

Due to the modular design of all devices of the SAG 410 series, the user can easily dismount and change the feeding and dispersing unit against one with a different feeding range. (see Figure 2).

The injector can be easily and rapidly exchanged separately too. Detailed information is available from the manufacturer.

Feeding and Dispersing Unit

This unit comprises the components for dosing as well as the dispersing unit. The dispersing unit consists of the injector and a tube for compressed air supply as well as a ground wire, both for connection to the housing.

The whole feeding and dispersing unit can be easily dismantled for cleaning, repairing or changing the unit against one with a different feeding range.

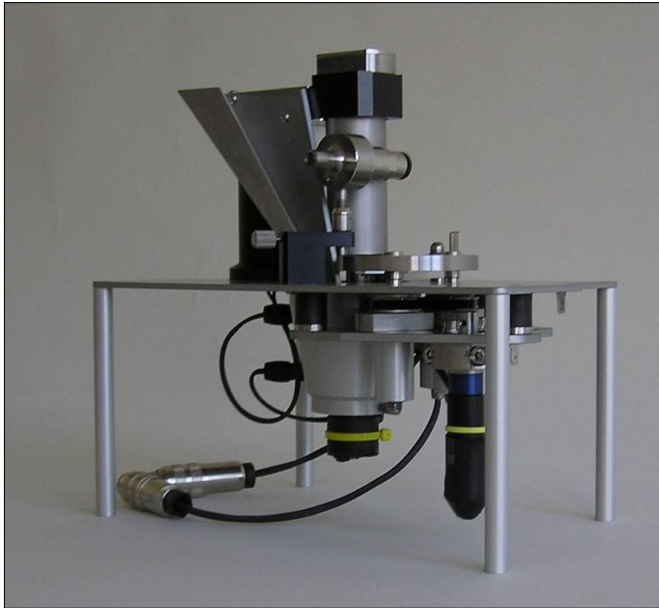

Figure 3: Feeding Unit with Injector (Dispersing Nozzle) SAG 410/U

The injector (dispersing nozzle) is plugged on the feeding unit and fixed with a knurled screw. In this way it can be easily dismantled and cleaned or replaced by another injector of the same type.

Dosing

Dosing the powder is done by a special dosing body which is charged with the powder. Charging is done in a 'drizzling' manner. Depending on the bulk characteristics of the solid powder (especially the bulk cone) a defined charge will be obtained i.e. the maximum amount the dosing body can be charged with. The powder on the dosing body (rotating dosing ring) is carried from the charging/overcharging site at a constant speed to the sucking dispersing nozzle. The rotation speed of the dosing ring can be freely selected.

Changing the height of the feeder with the mounted wiper by means of an adjusting screw enables the leveling of the shaped body of powder at the dosing ring.

This way a constant mass flow of the powder is available at the dispersing nozzle (the extraction site). The excess powder which does not remain on the dosing body falls down into the reservoir and is carried again to the charging/overcharging site for further feeding (circulation principle). The feed mass depends on the speed (revolutions) of the rotating ring and the geometric shape of the dosing body.

For dispersion the dosed powder is extracted by suction from the dosing ring by means of a dispersing nozzle and fed into the carrier gas. Shear forces created in this injector disperse and deagglomerate the powder to form an aerosol.

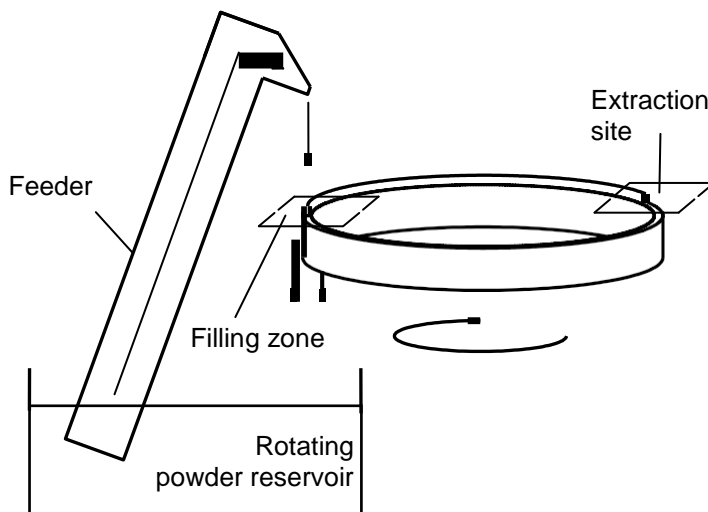

Figure 4: Principle of the SAG 410/U

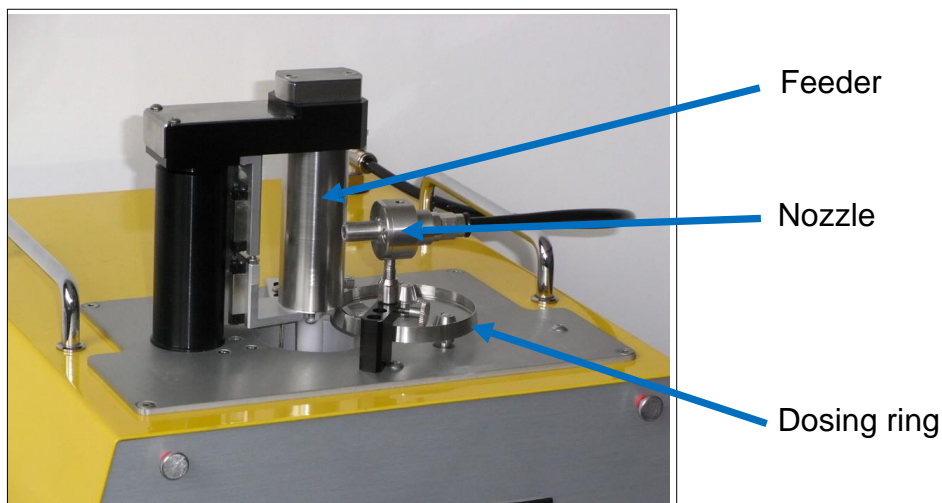

Figure 5: Dispersing nozzle mounted on the SAG 410/U

Control Unit

The control unit is separately covered in the instrument housing of the powder disperser for protection from dust. The control unit is connected to the feeding and dispersing unit by means of control cable and compressed air hose. All important functional components can be found at the front panel of the instrument:

- rotary switch “CONTROL” for choosing the control mode
- one button „SET / ACTUAL“, the display and the turning knob “FEED RATE” for adjusting and control/checking of the dosing (dosing ring speed)
- turning knob “PREPARATION” for controlling the feeding unit speed
If the motor is working beyond the range of its specification, a signal tone will indicate this trouble.
- inlet for compressed air
- a special interface for external control of the device (SUB-D-Socket 15Pins) (description: see Appendix of this manual)

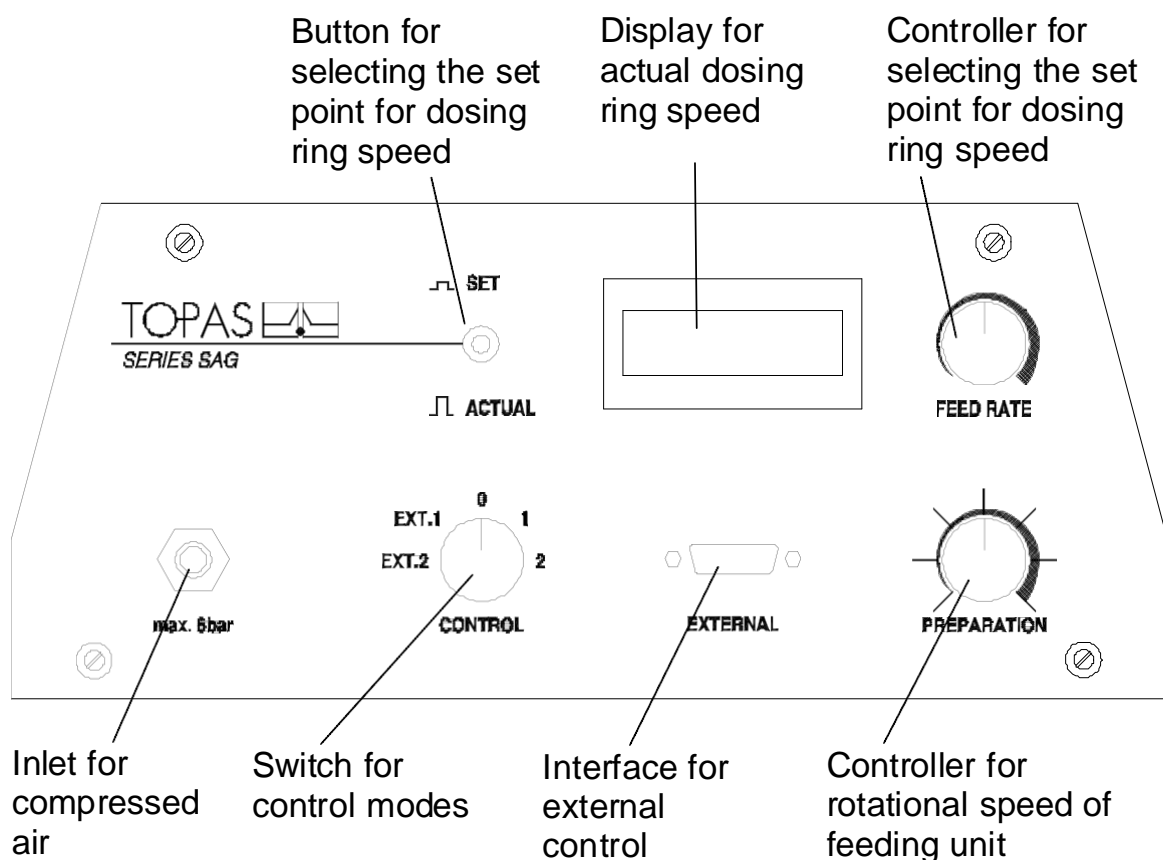

Figure 6: Front Panel of the SAG 410/U

Rotary switch “CONTROL” for Control Mode

To choose one of the five control modes the rotary switch “CONTROL” must be set in one of the five positions which are described in following table.

| | |
|-------|---|
| 0 | All components are switched off. The display shows the value „0“. By pushing the button „ACTUAL/ SET“ the last selected set value for the ring speed will be displayed. It can be changed by moving the turning knob „FEED RATE“ while pushing the button „ACTUAL/ SET“. |
| 1 | Feeding unit and dispersing unit are switched on. The speed can be selected with the turning knob „PREPARATION“. Change the volumetric flow by setting the inlet pressure. |
| 2 | Additional to mode „1“ the dosing ring is activated. The pre-adjusted set value for the ring speed is set and is shown in the display. It can be changed by using the turning knob „FEED RATE“. The set value is selected by simultaneously holding the button "ACTUAL/SET". |
| EXT.1 | All components are switched off. By using an external switch they can be switched on via the interface. The device is working according to the set values preadjusted in control mode “1”. For configuration of an external controller the interface is described in the appendix of this manual. |
| EXT.2 | All components can be controlled by using an external controller via the interface. For configuration of an external controller the interface is described in the appendix of this manual. |

Button „ACTUAL/SET“, Display and Turning Knob „FEED RATE“ for Dosing Ring Speed

The button „ACTUAL/SET“ is used to operate the display. When pressing this button the preselected set value for the dosing ring speed is shown on the display. That means the set value can be pre-selected even in the control modes „0“ and „1“ (dosing ring switched off). For this reason the button „ACTUAL/SET“ has to be pressed and at the same time the turning knob „FEED RATE“ is adjusted. During dosing the accordance of actual value and set value can be checked by pressing the button.

Turning Knob “PREPARATION” for feeding unit

The speed of the feeding unit (consisting of feeder and rotating powder reservoir) can be selected with the turning knob “PREPARATION”. The optimum value depends on the properties of the powder (bulk characteristics). It can be found out by some tests.

Compressed Air Supply

The compressed air supply can be connected to the inlet on the front panel of the SAG 410/U.

Caution: *To protect the internal components of the device) do not connect a compressed air supply with more than 6 bar (6×10^5 Pa) operation pressure.*

With the pressure regulator, which is part of delivery, the injector-pressure can be adjusted to get a good dispersion of the powder. If the injector-pressure decreases below 1 bar (1×10^5 Pa) the controller stops any action of the dosing ring because under such conditions the injector cannot take up and disperse the powder.

Interface for External Controlling – “EXTERNAL”

Via the interface „EXTERNAL“ (SUB-D-Socket 15Pins) on the front panel the Solid Aerosol Generator can be externally controlled. For this operation the switch “CONTROL” must be set on “EXT.1” or “EXT.2”. The description of the interface can be found in the appendix.

3 Operation and Maintenance

Unpacking

After unpacking the completeness of the consignment should be checked.

The standard scope of supply comprises:

- SAG 410/U
- Mains cable
- Pressure regulator
- Quick coupling
- Instruction manual
- 2 Dosing rings: 0.3 mm and 1.0 mm

Please contact Topas GmbH if any items are missing or appear to be damaged.

Start up and Operation

The device is set into operation as follows:

1. Place the SAG 410/U on even and rigid surface.
 2. Connect the SAG 410/U with the external pressure regulator to the compressed air supply.
-

Caution: *The inlet pressure must not be higher than 6 bar (6×10^5 Pa).*

3. Check the connection of the protection wire to the dispersing unit (injector) before operating the aerosol generator. Connect the power cord first to the instrument before connecting to the power supply.
-

Caution: *During operation electrostatic charging is possible. Before operation check the proper attachment of the protective earthing conductor (designated by the green-yellow insulation) to the dispersing nozzle.*

4. Set "CONTROL" to position "0"
5. Set "PREPARATION" to position 50 %
6. Set "FEED RATE" to position 0 % (extreme left position)
7. Switch on the unit
8. Set "CONTROL" to position "1", dispersing unit, reservoir rotation and feeder are switched on

9. Fill reservoir with powder (max. filling level in the reservoir ca. 90%); an optional funnel can be used for more convenient filling.

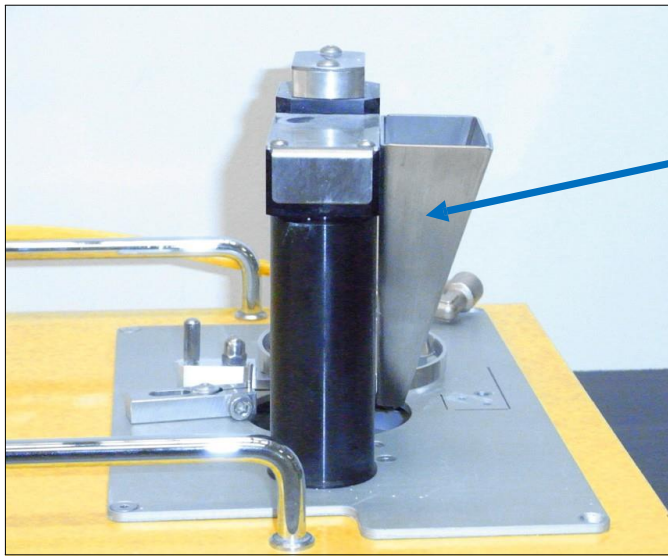

Funnel for more convenient filling

Figure 7: Funnel (optional)

10. Check the behaviour of the powder at rotating reservoir (the lower opening of the feeder must be covered, but the powder must not reach the upper rim of the reservoir).

11. Place the dosing ring (see following figures)

NOTE: The feeding ring must be free of grease, otherwise powder would stick to the dosing ring (degreasing can be done with ethanol)

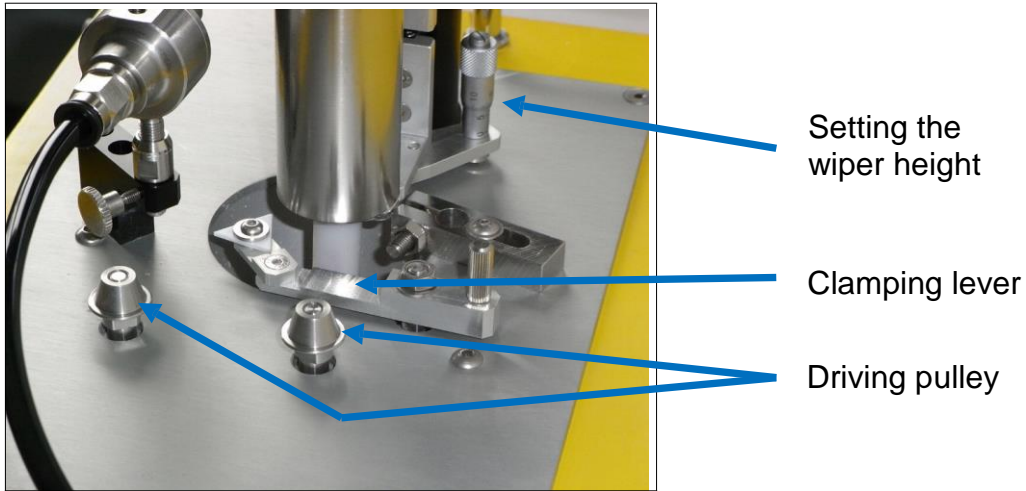

Figure 8: Dosing Mechanism without Dosing Ring

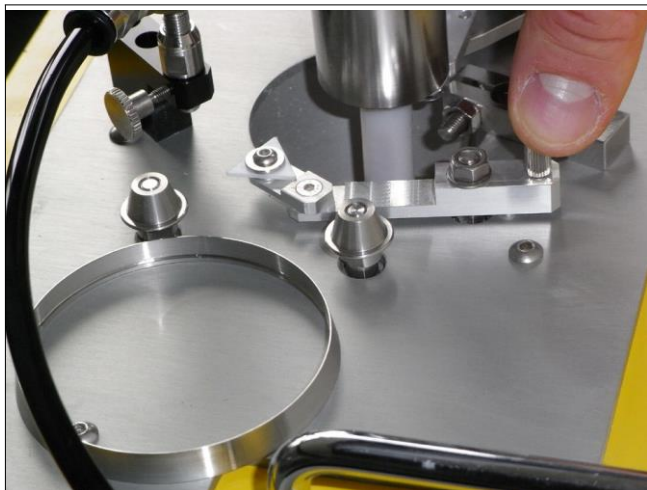

Figure 9: Using the Clamping Lever

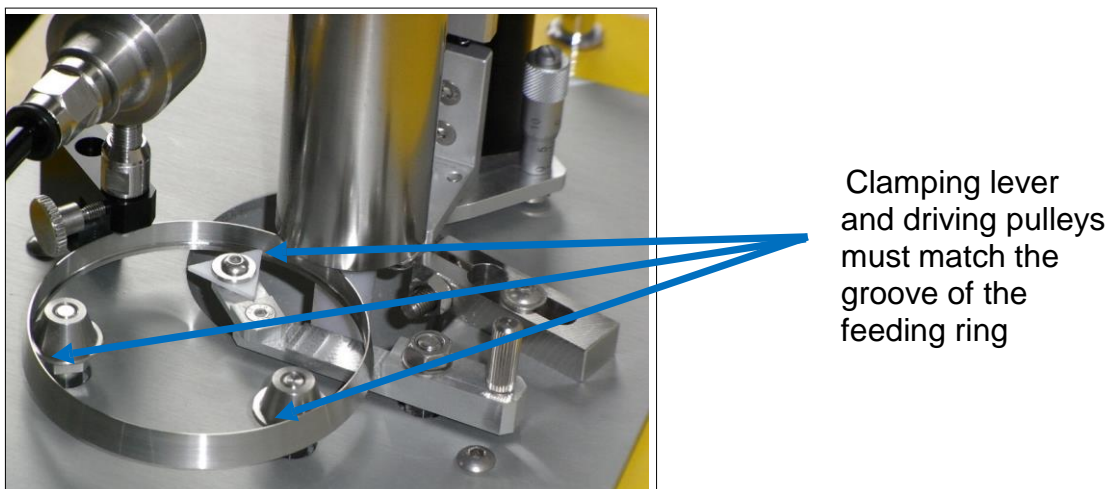

Figure 10: Dosing Ring in Operating Position

12. The height of the dispersing nozzle (injector) is set so that the intake opening of the dispersing nozzle does not get into contact with the dosing ring but can suck in the powder completely (see figure).

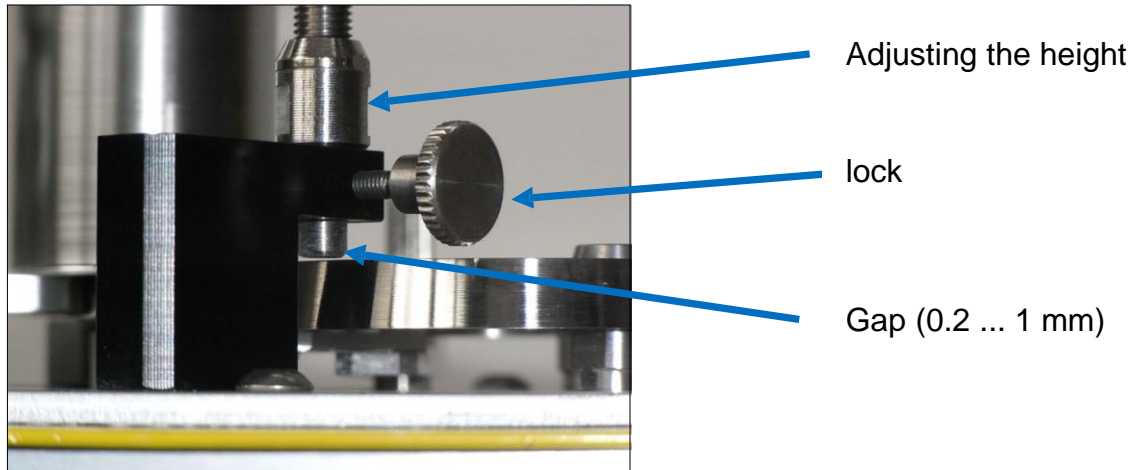

Figure 11: Adjusting Dispersing Nozzle I

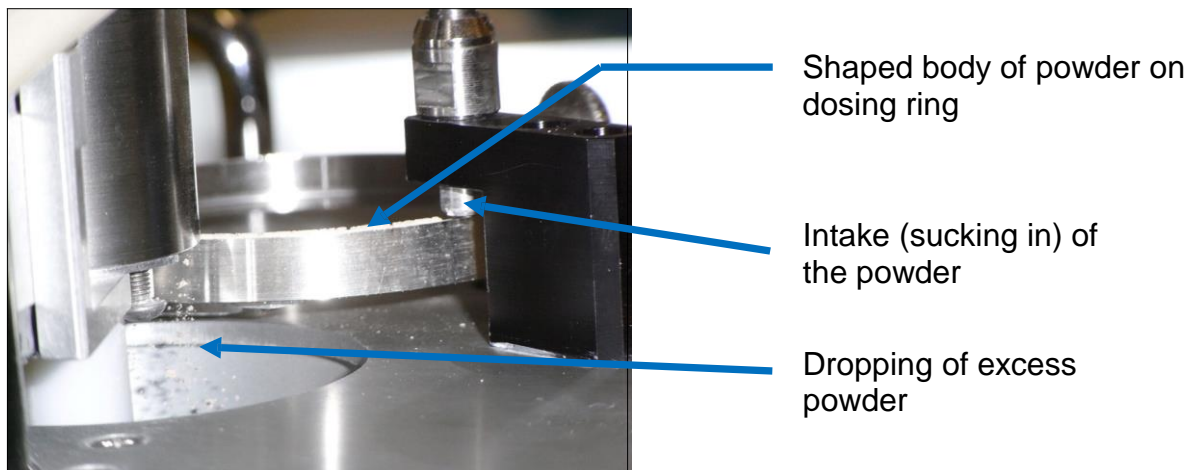

Figure 12: Adjusting Dispersing Nozzle II

13. Adjust the height of the wiper to evenly distribute the dosed amount.
14. Set "CONTROL" to position "2"

- Volumetric flow and reservoir rotation are activated
- The feeder supplies the powder which drops over the dosing ring.
- Set "FEED RATE" for the dosing ring to rotate
- The dosing ring is now being charged with powder. Reducing the wiping height by means of the adjusting screw (Figure 8) the desired height of the powder can be set. (It is recommended to ensure a homogeneous powder charging without any spaces and at uniform height, see Figure 8)

Important: *The injector must not be in contact with the dosing ring (Danger of blocking the dosing ring). Before delivery nut and counter nut are adjusted by the manufacturer. Their position must not be changed by the user.*

Operation

For the operation of the SAG 410/U the following important notes should be taken into consideration:

The dosing ring must be free of grease: cleaning with ethanol is recommended as well as wearing of foil gloves for setting in and manipulating

The filling level in the reservoir must not be too low (performance of the feeder drops) or is too high (risk of overflowing)

The rotation speed (revolution) must not become too low for the respective powder dosing (not lower than 2...5 %), otherwise the intake of the powder from the ring by the nozzle would become irregular. If smaller feeding amounts are desired a smaller dosing ring should be used.

The height of the nozzle should be adjusted to allow the complete intake of the powder from the ring but must not touch the ring.

The wiper is adjusted at a height to obtain a uniform height of the powder without spaces

The revolution of the feeding unit is set to allow a sufficient powder supply in order to overfill the ring. Higher revolutions are not necessary. This would only increase the stress of the mechanical components and the powder.

Items influencing the feeding amount

- Rotating speed of the dosing ring
- Geometrical shape of the dosing ring
- Wiping height above the ring
- Bulk characteristics of the powder
- Revolution of the feeding unit

Items influencing the feeding consistency

- Circular mass flow through the feeding unit with continuous reuse of excess powder:
The mass flow must be high enough to overfill the dosing ring.
- Wiper height: the flowing behaviour of the powder has to be taken into consideration when selecting the height; avoid scraping of the powder off the ring resulting in inhomogeneous level of the powder.
- Sufficient rotation speed of the dosing ring; otherwise the intake of powder by the dispersing nozzle would not be constant.

Maintenance

In case there are remains of powder on the instrument's bottom the rear panel can be dismantled by unscrewing the 4 knurled screws and cleaned afterwards.

After operation the instrument (SAG) must be carefully cleaned. It can be done in the following way:

1. Switch off and disconnect the device from the mains
2. Unscrew the knurled screws at the rear panel and pull out the collecting vessel
3. Unscrew the 4 screws in the feeding and dispersing unit and take the unit out of the instrument by lifting it upwards. Disconnect motor cable and potential equalization from the device.

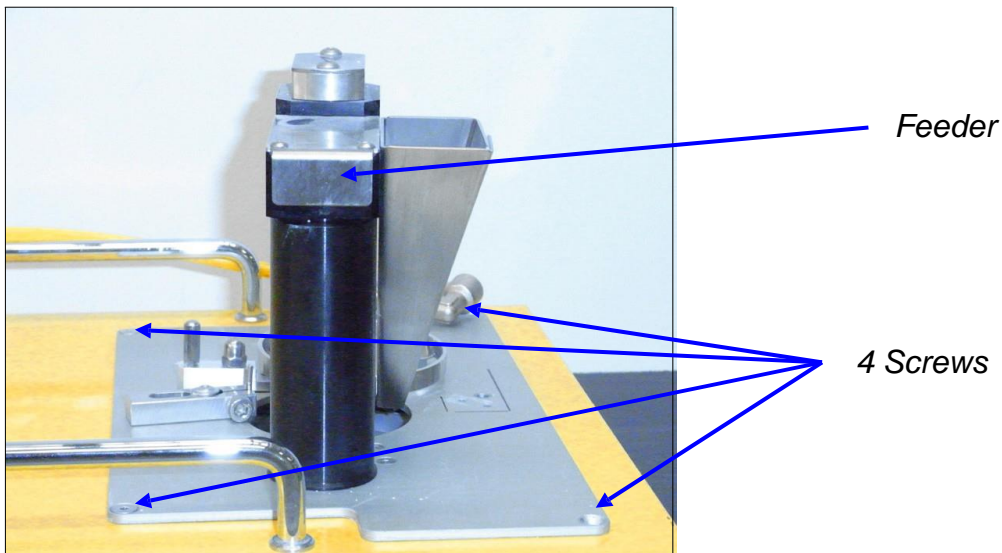
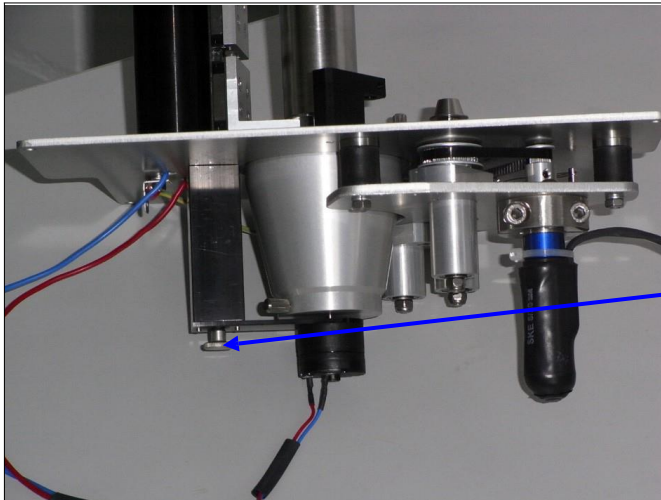

Figure 13: Dismounting Feeding and Dispersing Unit

4. Remove the dispersing nozzle from the feeding unit (unscrew knurled screw)

5. Unscrew knurled screw at the holding plate and at powder reservoir and pull out the reservoir downwards.



Unscrew knurled screw to take out Powder Reservoir

Figure 14: Dismounting Powder Reservoir

6. The reservoir can now be emptied and cleaned.
7. Take out the feeding unit by lifting it upwards and clean it (Figure 13).
8. Clean all components with compressed air and a dry cloth.
9. Mount all components again.

Injector (Dispersing Nozzle)

After long operation periods the injector should be checked for damages caused by erosion. The life time of the injector depends of the properties of the dispersed powders. If the aerosol material is not extracted completely from the feeding belt, then check if the injector is worn out and has to be replaced by a new one.

New injectors can be ordered from Topas GmbH.

Dismounting and Mounting Feeding and Dispersing Unit

For cleaning the feeding and dispersing unit or for changing it against another having a different feeding range the feeding and dispersing unit can be dismantled.

This can be done in following steps:

1. Pull out the mains cable.
2. Dismount the dispersing nozzle (injector) by unscrewing the knurled screw.
3. Unscrew the knurled screws of the rear panel and remove it.
4. Pull out both control wires placed inside the powder disperser.
5. Unscrew the screws on the upper side of the feeding unit.
6. Remove the feeding and dispersing unit.

Mounting the feeding and dispersing unit can be done with the same steps in reverse order.

Transport

The SAG 410/U is a very compact, rugged and reliable instrument which can be easily transported in its original packing.

Protection of dispersing unit (injector and cable) as well as dosing ring drive during the transport is recommended by the manufacturer.

4 Feeding and Dispersing

Operation of the SAG 410/U

Caution: *Check the connection of the protection wire (green/yellow coloured) to the dispersing unit (injector) before operating the aerosol generator SAG 410/U. Make also sure that the produced aerosol is removed after the test. If the aerosol should be generated into a duct or something like that, this apparatus also should be protected accordingly. The exhaust system must be switched on.*

1. Connect the power supply and the compressed air supply to the SAG 410/U.
2. Switch on the SAG 410/U on the instrument's right side.
3. Fill the powder into the powder reservoir.
4. Install the injector into the feeding unit by means of the knurled screw. Check the proper attachment of the protective earthing conductor to the dispersing nozzle.
5. Turn the rotary switch "CONTROL" to position "1". The feeding unit starts now and its speed can be adjusted with the turning knob "PREPARATION". The volume flow is unlocked.
6. Adjust the inlet pressure to more than 1 bar (1×10^5 Pa), otherwise the feeding unit is blocked by a safety control mechanism because a proper sucking from the dosing ring is not ensured. Characteristics of the nozzles (Flow rate vs. pressure): see Appendix of this manual.
7. Choose the dosing ring speed (0 ... 100%) by simultaneously pushing the button "ACTUAL/SET" and adjusting the controller "FEED RATE". For defined feeding masses, the SAG must be calibrated with the needed powder (see chapter "Calibration").
8. Turn the rotary switch "CONTROL" on position "2". The dosing ring starts with feeding the powder.

Stopping the Aerosol Generation

1. Turn the rotary switch "CONTROL" on position "0".
Feeding unit, dosing ring as well as compressed air supply are switched off in this position.
2. Close or disconnect the external compressed air supply.
3. Switch off the power switch.

Calibration of the Feeding Unit

The feeding mass of the powder is defined by the ring speed, the geometric shape of the dosing ring as well as the powder bulk density. That is why the users have to determine the dependency between ring speed and feeded mass for every new powder themselves.

A solution for calibration of the SAG 410/U is to disperse the powder with various ring speeds in a special channel with a suitable filter (see Figure 15). The dependency between the mass flow and the ring speed can be calculated by determining the mass changes of the filter. For calibrating the SAG 410/U the following steps are recommended:

Calibration steps

1. Determine the mass of a suitable filter.
2. Insert the filter into the channel.
3. Generate aerosol into the channel with one belt speed and measure the time.
4. Determine the filter mass again and note the data in following table.

| Ring Speed [%] | Primary filter mass [g] | Measuring time [s] | Filter end mass [g] | Differential mass [g] |
|-------------------|----------------------------|-----------------------|------------------------|--------------------------|
| 25 | 30 | 300 | 45 | 15 |
| 40 | ... | ... | ... | ... |
| ... | | | | |
| ... | | | | |
| ... | | | | |
| ... | | | | |

5. Repeat this routine with the subsequent different ring speeds.

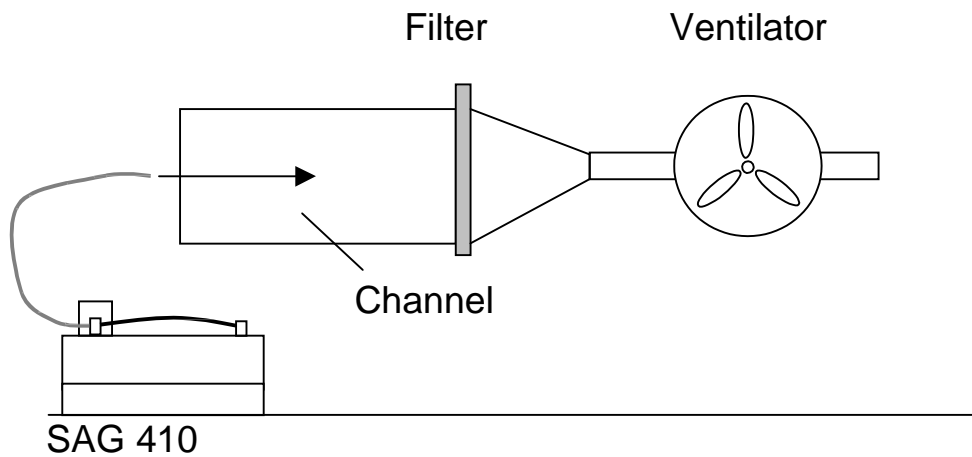

Figure 15: Apparatus for Calibration of the SAG 410/U

Once all calibration data is determined it should be shown as a calibration function in a diagram.

Figure 16 shows an example of such a calibration function for a selected powder.

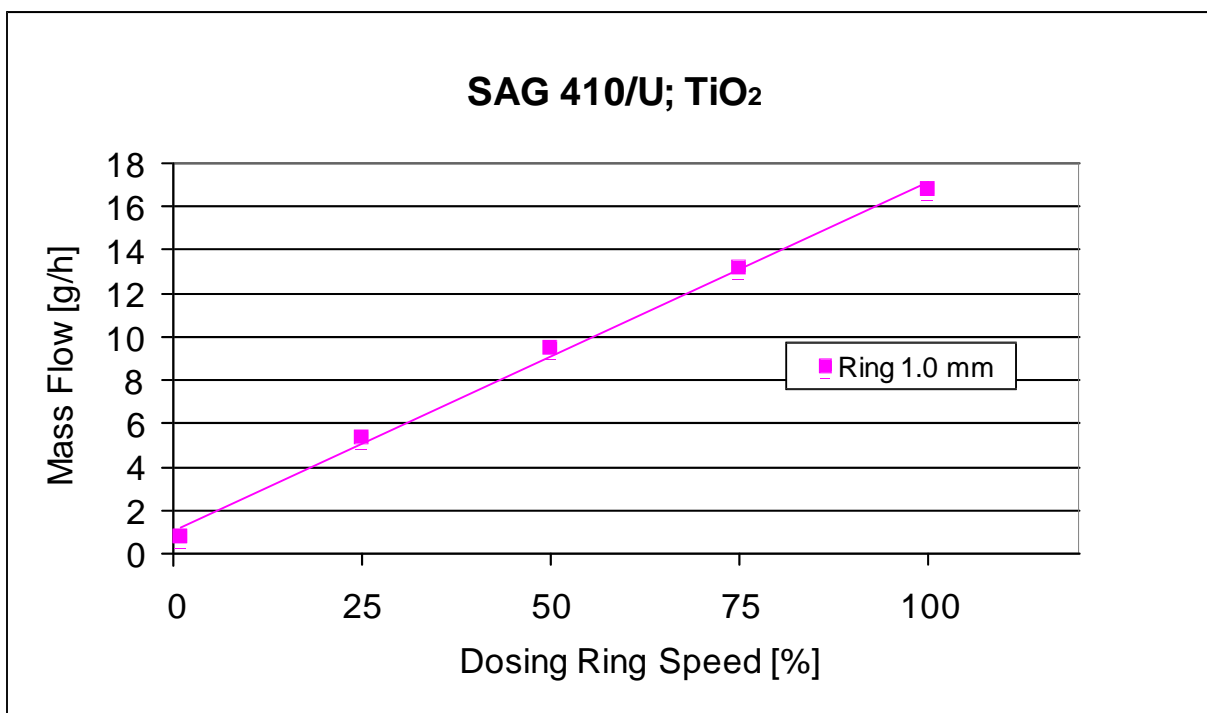

Figure 16: Example for Calibration Function for Titanium dioxide (SAG 410/U)

5 Troubleshooting

| Problem | Possible Cause | Suggested Solution |
|--|---|--|
| Display does not light after switching | No power supply | Check Power supply |
| | Fuse faulty | Change the fuse: disconnect cable, take out fuse |
| | Control unit fails | Contact Topas service |
| Dosing ring does not work | Dosing ring blocked by powder | Cleaning; check if powder is suitable see: safety remarks |
| | Inlet pressure <1 bar | Adjust the inlet pressure to more than 1 bar |
| | Feeding unit faulty | Contact Topas service |
| | Dosing ring blocked because of contact with dispersing nozzle | Adjust distance between dosing ring and dispersing nozzle |
| Injector does not completely empty the dosing ring | Dispersing nozzle not mounted properly | Check distance between dispersing nozzle and dosing ring and adjust it |
| | Dispersing nozzle blocked up | Clean dispersing nozzle |
| | Dispersing nozzle worn out | Replace dispersing nozzle |
| | Compressed air supply to the injector is loose | Check the tightness of the tube connection |

| | | |
|--|---|--|
| <p>Feeding unit and/or dosing ring do not work and a beep sound is heard</p> | <p>Protection: one of the feeding units is overloaded</p> | <p>Check if the feeding unit or dosing ring are blocked up, reset the rotary switch "CONTROL" in position "0" or completely switch off and on the SAG for operating it again</p> |
| <p>Feeding unit does not work</p> | <p>Feeding unit faulty</p> | <p>Contact Topas service</p> |

6 Specification

Technical Data

| | |
|---|---|
| Maximum filling amount | 70 cm ³ |
| Maximum particle size | 100 µm |
| Test dusts | ISO 12103-A4 (Coarse), ISO 12103-A2 (Fine), Cellulose, Calcite, Furnace Black, Titanium dioxide, Aluminium oxide |
| Aerosol flow rate | 1.5 ... 4 m ³ /h |
| Powder mass flow (dependent on bulk density of the test dust, dosing ring speed and feeding unit speed, geometry of the dosing ring and other parameters) | <p>Exemplary:</p> <p>PURAL SB: min. 0.21 g/h (Ring 0.5 mm) max. 18.69 g/h (Ring 1.0 mm with notch)</p> <p>TiO₂: min. 0.27 g/h (Ring 0.5 mm) max. 16.8 g/h (Ring 1.0 mm)</p> <p>Furnace Black 101: min. 0.072 g/h (Ring 0.5 mm) max. 6.84 g/h (Ring 1.0 mm)</p> <p>JIS 11 min. 0.294g/h (Ring 0.75 mm with notch) max. 7.1 g/h (Ring 0.75 mm with notch)</p> <p>ISO 12103-A2 (Fine) min. 0.5 g/h (Ring 1 mm) max. 8.8 g/h (Ring 1 mm)</p> |
| Compressed air supply | min. 1 bar / 100 kPa max. 6 bar / 600 kPa |
| Power supply | 100 ... 260 V AC 47...63 Hz |
| Fuse | 2 x 4 F (next to mains) |

| | |
|--|--------------------|
| Dimensions (W x D x H): SAG 410/U | 320 x 400 x 260 mm |
| Weight SAG 410/U | Approx. 10.4 kg |
| Weight feeding and dispersing unit SAG 410/U | Approx. 1.9 kg |

Accessories (optional)

- Remote Control Unit RCU 411
- Dosing rings (for various mass flows)

7 Appendix

Option Remote Control

Example 1 for Setting External Control via Interface

Control Mode „EXT.1“ (Switching ON/OFF)
 (Rotary switch „CONTROL“ in position „EXT.1“)

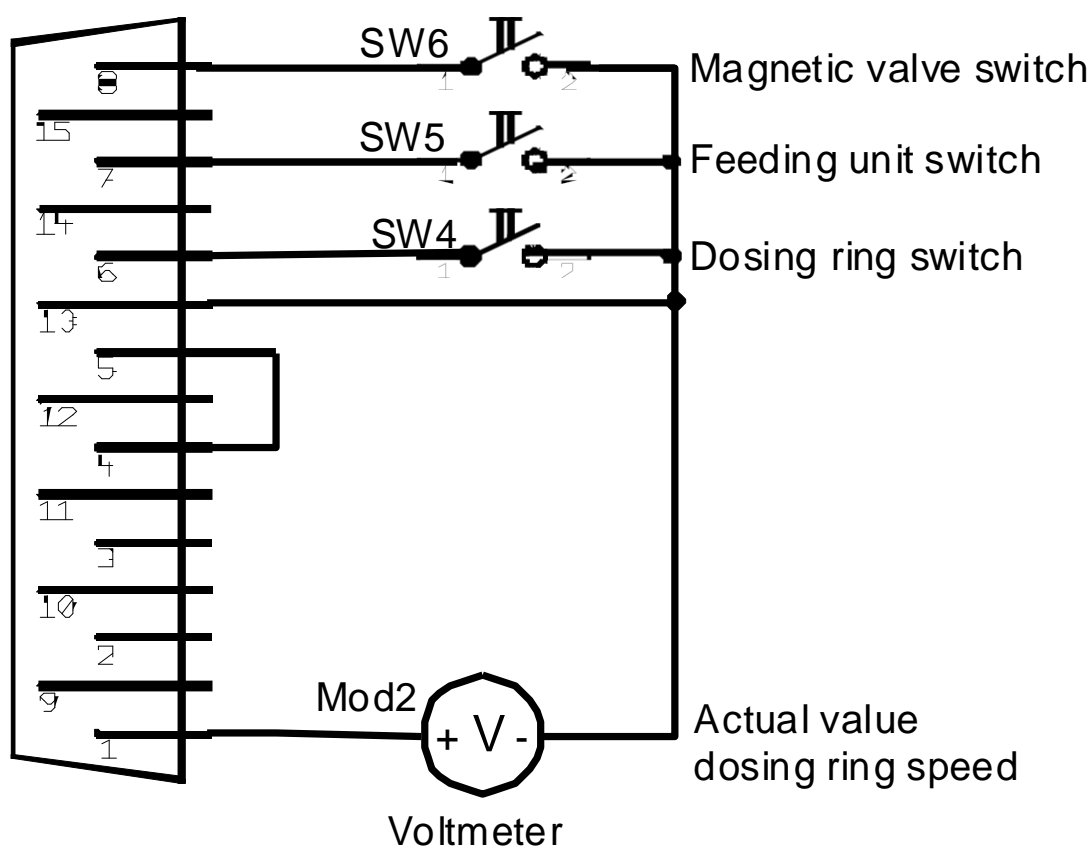

SUB-D-Socket 15Pins

Set point values for dosing ring speed and feeding unit speed are transferred from the turning knobs „FEED RATE“ and „PREPARATION“ (at the front panel of the device).

Example 2 for Setting External Control via Interface

Control Mode „EXT.2“ (complete control)
 (Rotary switch “CONTROL” in position “EXT.2”)

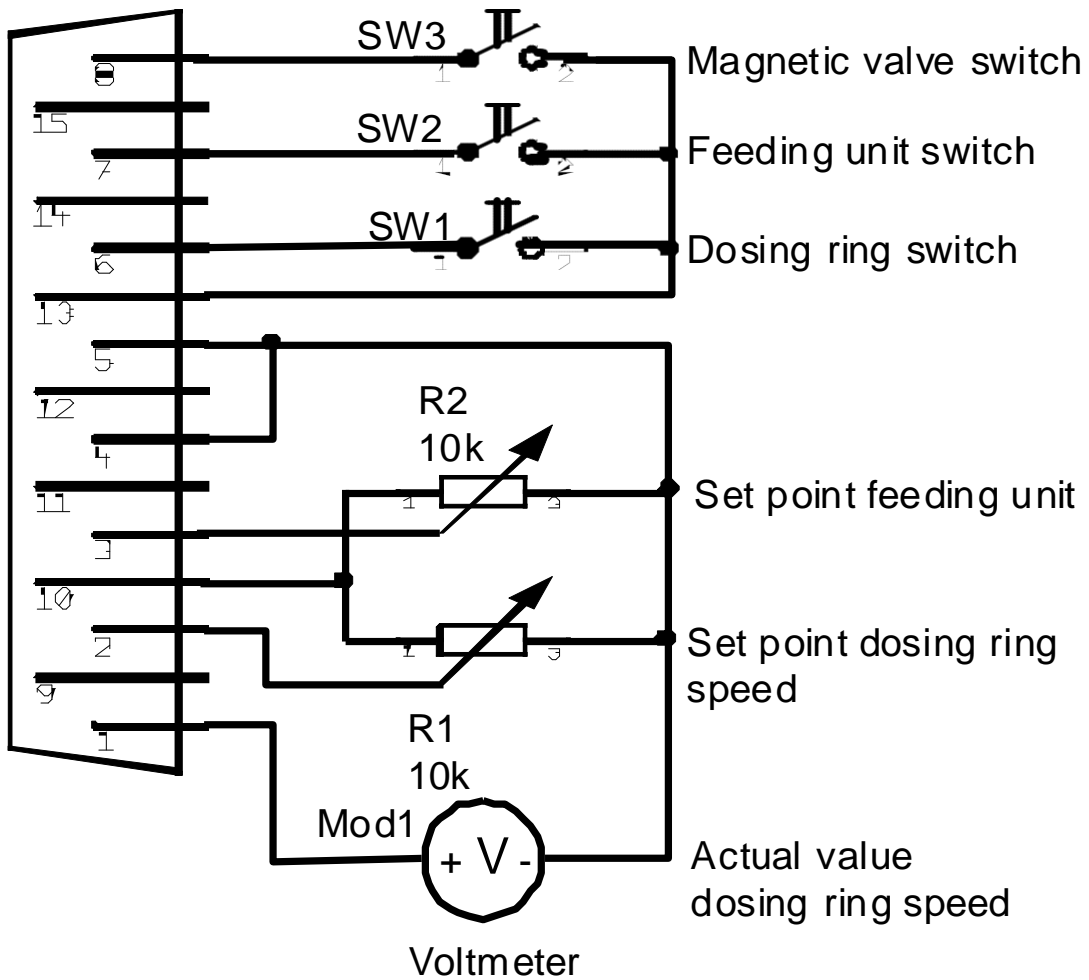

SUB-D-Socket 15Pins

Description of the Interface (SUB-D-Socket 15 Pins)

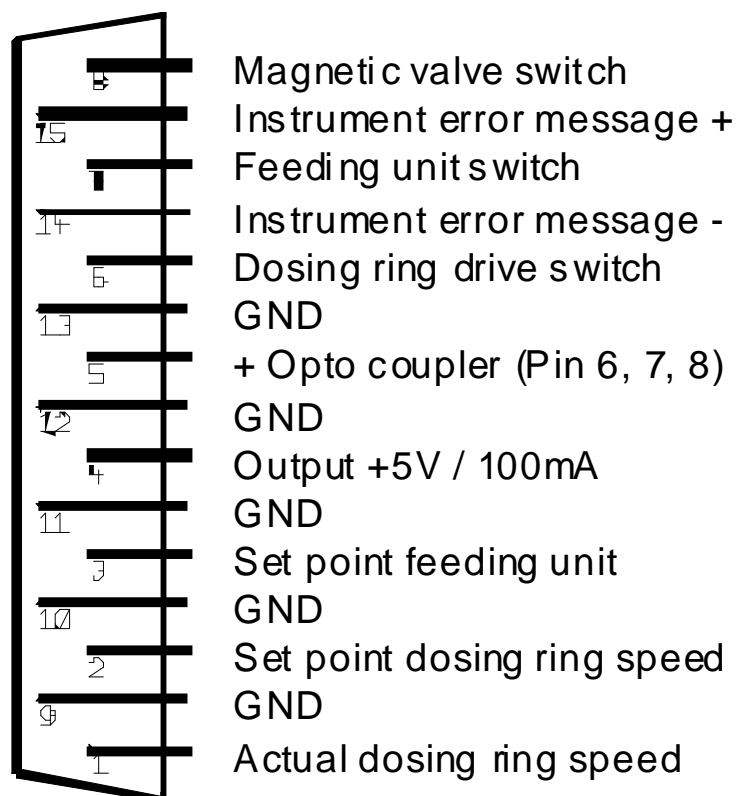

Specifications for Interface (D-SUB- 15 Pins)

| Pin-No.: | Name: | Level: | Information: |
|-------------------|---|-----------------------------|-----------------------------------|
| 1 | actual dosing ring speed | 0 ... 4,5 V ⇒ 0 ... 100% | R _{min} 1 kΩ |
| 2 | set point dosing ring speed | 0 ... 5 V | max. 30 V |
| 3 | set point feeding unit | 0 ... 5 V | max. 30 V |
| 4 | supply voltage | +5 V / 100 mA | |
| 5 | common + Pin for optocouplers (Pin 6, 7, 8) | 5 ... 24 V | |
| 6 | dosing ring switch | | potential free via optocoupler |
| 7 | feeding unit switch | | potential free via optocoupler |
| 8 | magnetic valve switch | | potential free via optocoupler |
| 9, 10, 11, 12, 13 | GND - Reference | | |
| 14, 15 | potential free instrument error message -,+ | 10 mA, max. 30 V | instrument error = circuit closed |

Characteristics of the Dispersing Nozzle

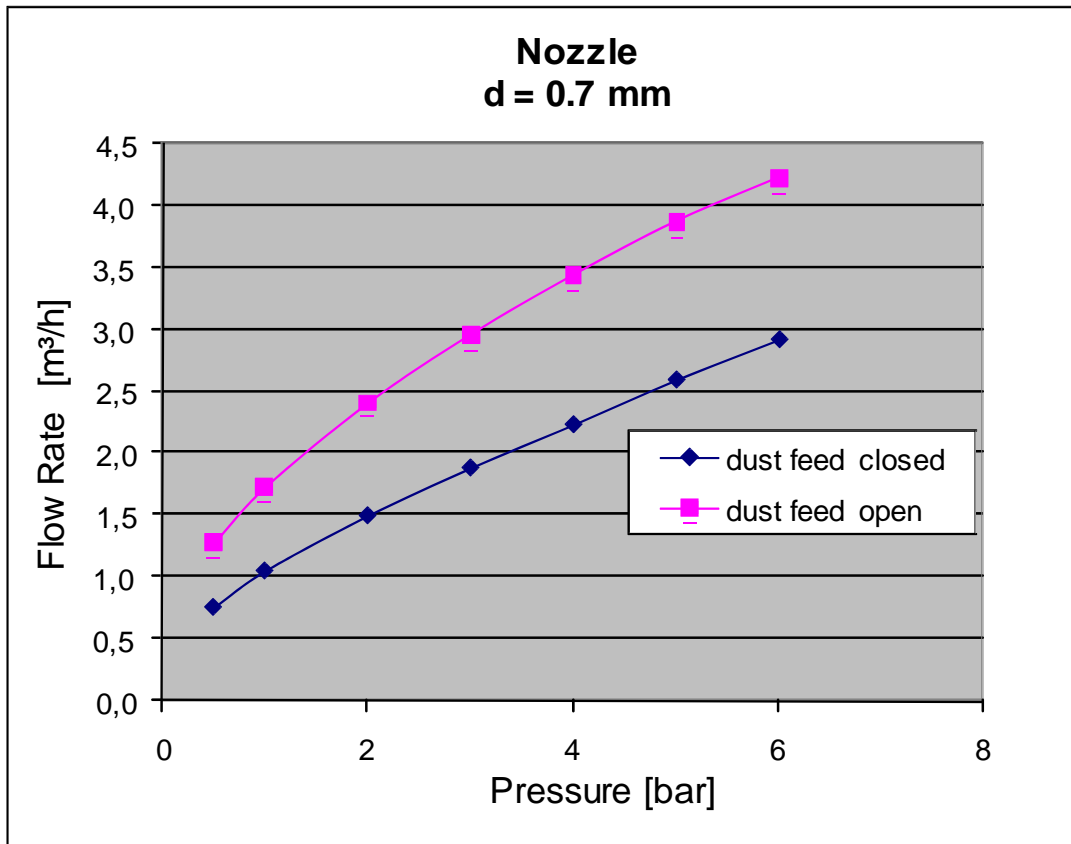

Figure 16: Characteristics of the Standard Nozzle



Figure 17: Standard Nozzle

EG-Konformitätserklärung

Hiermit erklären wir, dass der Staubgenerator Serie SAG 410/U und SAG 410/P in der von uns in Verkehr gebrachten Ausführung folgenden EG-Richtlinien entspricht.

Maschinenrichtlinie 2006/42/EG vom 17.5.2006

Angewandte harmonisierte Normen: EN ISO 12100-1
EN ISO 12100-2

Richtlinie Elektromagnetische Verträglichkeit 2004/108/EG vom 15.12.2004

Angewandte harmonisierte Normen: EN 50081-1
EN 50082-1

Die Schutzziele der Niederspannungsrichtlinie wurden gemäß Anhang I, Nr. 1.5.1 der Maschinenrichtlinie eingehalten.

Bei einer mit uns nicht abgestimmten Änderung am Gerät verliert diese Erklärung ihre Gültigkeit.

EC Declaration of Conformity

We confirm that the conception and the design of the Solid Aerosol Generator Series SAG 410/U and SAG 410/P meet the requirements of the following guidelines of the European Community (EC).

EC-Directive machinery 2006/42/EG (17 May 2006)

Harmonizing standards: EN ISO 12100-1
EN ISO 12100-2

EC-Directive for electromagnetic compatibility 2004/108/EG (15 December 2004)

Harmonizing standards: EN 50081-1
EN 50082-1

The safety objectives of the Low Voltage Directive in accordance with Annex I, No. 1.5.1 of the Machinery Directive are satisfied.

This declaration is no longer valid if the instrument has been modified without a written permission of the Topas GmbH.

Topas GmbH

Dresden, den 23.11.2009



Dr.-Ing. Andreas Rudolph
Geschäftsführer
Managing Director

